

PIC Wire & Cable	Connector Specification	P/N 110783
<i>A Division of the Angelus Corporation</i> Ph (262) 246-0500 Fax (262) 246-0450 www.picwire.com PO Box 330 Sussex, WI 53089	Approved : <i>PFT</i>	Date : 10/22/19
	Distribution : User	Rev. 0
		Uncontrolled if Printed

HD-BNC Straight Bulkhead Jack

For V76261, V75268, & V73263 Cables

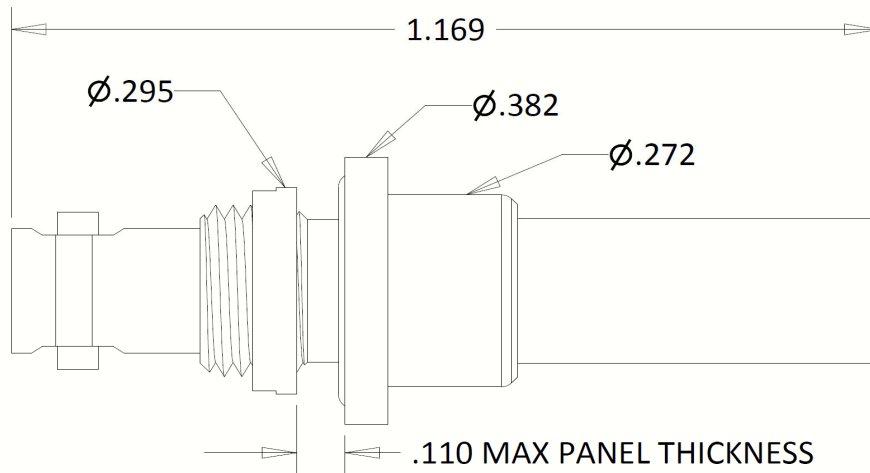

PERFORMANCE

Impedance	75 Ohm
Frequency Range	DC - 4 GHz
Dielectric Withstanding	1000 VRMS, min
Insulation Resistance	10,000 MOHMs, min

ENVIRONMENTAL

Temperature Rating	-65° C to +165° C
Insertion / Extraction	500 cycles min

CONNECTOR WEIGHT (Each)

0.254 ounces (7.20 grams)

RoHS COMPLIANT

Complies to RoHS Standards

REQUIRED TOOLING

M22520 / 5- 01 Hex Crimp Tool
M22520/ 5-41, cav. B (.178" hex)
Daniels # Y1833P Die Set (.042" square crimp)

CONSTRUCTION

Materials:

Body	Brass
Contact	Phosphor Bronze
Ferrule	Copper
Insulator	PTFE
O-Ring	Silicone Rubber

Finishes :

Contact	Gold
Body, Ferrule	Nickel

APPLICABLE STANDARDS

Amphenol Interface Std 349-50820

Notes:

- (1) A 1.50" piece of Raychem ATUM heat shrink P/N ATUM-8/2-0 provided with connector for purpose of strain relief & moisture protection.
- (2) Please refer to T-110783 Termination Instruction sheet for strip dimensions & instructions.