

<b>PIC Wire &amp; Cable</b>	<b>Connector Specification</b>	<b>P/N 190424</b>
A Division of the Angelus Corporation Ph (262) 246-0500 Fax (262) 246-0450 www.picwire.com PO Box 330 Sussex, WI 53089	Approved : 	Date 06/25/97
	Distribution : USER	Rev. 4 (06/17/14)
		Uncontrolled Document

**N In-Line Straight Jack**  
for S22089

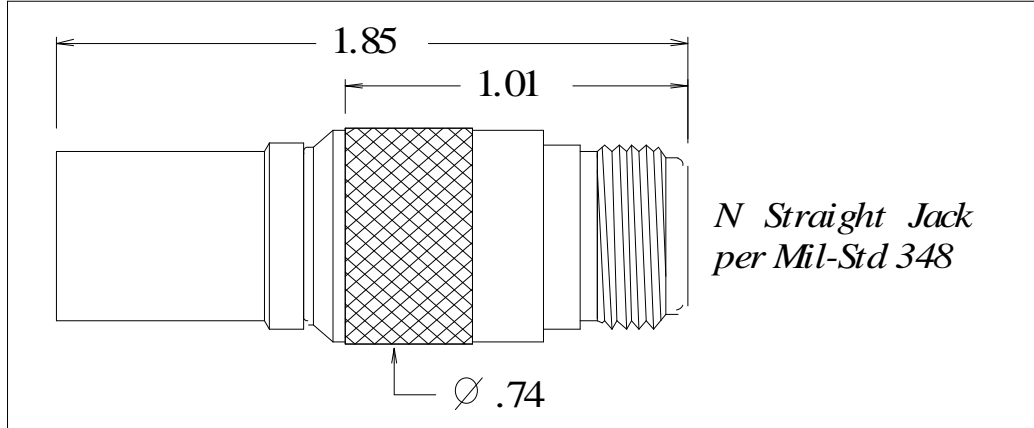

**PERFORMANCE**

Nominal Impedance	50 Ohms
Frequency Range	0 - 12 GHz
Voltage Rating	1000 VRMS
Insulation Resistance	5000 Megohms

**CONNECTOR WEIGHT (Each)**

1.57 ounces (44.51 grams)

**RoHS COMPLIANT**

Complies to RoHS Standards

**INSTALLATION**

<b>Pic Die Set</b>	<b>MIL Spec Die Set</b>
<i>Center Contact</i>	<i>Center Contact</i>
M22520 / 5 - 01 Tool, PIC 190418 Hex Crimp Die (.132 hex)	M22520 / 5-01 Tool, MIL Spec *M22520 / 5-04 (.138 A hex)
<i>Crimp Ferrule</i>	<i>Crimp Ferrule</i>
M22520 / 5 - 01 Tool, PIC 190418 Hex Crimp Die (.525/.562 hex)	M22520 / 5-01 Tool, MIL Spec *M22520 / 5-27 (.532 A hex)

\* Note - MIL Spec die to be used on the smaller diameter area of ferrule only. Not the larger "Bell" area on end.

**CONSTRUCTION**

**Materials:**

Body	Brass, ASTM-B16, Alloy UNS 36000, H02
Center Contact	Beryllium Copper, ASTM-B196, Alloy UNS C17300
Ferrule	Brass, ASTM-B16, Alloy UNS 36000, Dead Soft, Weatherseals included
Dielectric	TFE Fluorocarbon, ASTM-D1710, Type 1, Grade 1

**Finish :**

Body, Ferrule	Nickel
Center Contact	Gold

**Applicable Standards**

MIL-STD 348  
MIL-PRF-39012

**Notes :**

- 1) A 2.5" piece of Raychem ATUM heat shrink P/N ATUM-19/6-0 provided with connector for purpose of strain relief & moisture protection.
- 2) Please refer to T-190XXX Termination Instruction sheet for strip dimensions & instructions.

*PIC Wire & Cable Connector User specification sheets are non-controlled documents. Please contact PIC Wire and Cable or visit the PIC website (www.picwire.com) to ensure the latest revision of the drawing is being viewed.*