

# PIC Wire & Cable

A Division of the Angelus Corporation

Ph 262-246-0500

Fax 262-246-0450

PO Box 330 Sussex, WI 53089

## Connector Specification

190531A

Approved

JPY

Date 10/31/02

Rev. 1 (10/30/03)

Distribution : USER

### TNC 75° Plug for S65161

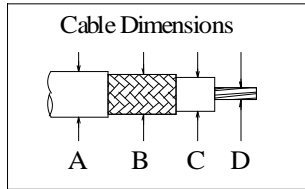

#### CABLE DIMENSIONS

A	Jacket (overall) O.D.	.195
B	Over-shields O.D.	.174
C	Dielectric O.D.	.147
D	Center conductor O.D.	.057

#### PERFORMANCE

Nominal Impedance	50 Ohms
Frequency Range	0 - 12 GHz
Voltage Rating	500 VRMS
Insulation Resistance	5000 Megohms

#### Force to Engage

Longitudinal	NA
Torque	2 in - lbs Max

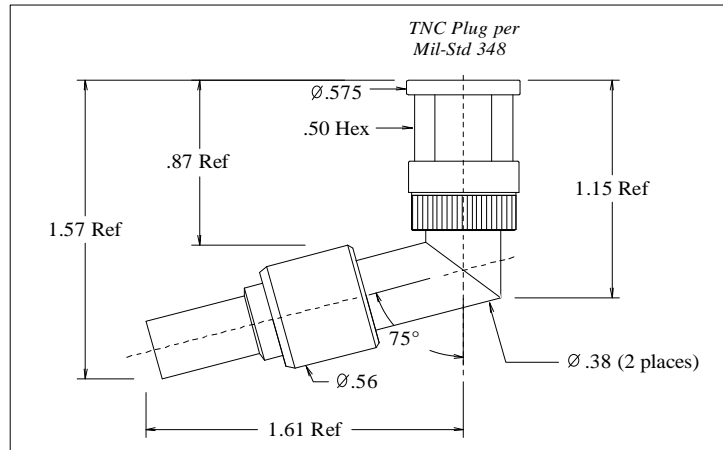

Features Not Shown: Safety Wire Holes, Seal in front

#### CONSTRUCTION

##### Materials:

Body	Brass, ASTM-B16, Alloy UNS 36000, H02
Center Contact	Beryllium Copper, ASTM-B196, Alloy UNS C17300
Ferrule	Brass, ASTM-B16, Alloy UNS 36000, Dead Soft, Weatherseals included
Dielectric	TFE Fluorocarbon, ASTM-D1710, Type 1, Grade 1

##### Finish :

Body, Ferrule	Nickel
Center Contact	Gold

##### Applicable Standards

MIL-STD 348  
MIL-PRF-39012

#### INSTALLATION

##### Crimp Tooling:

Center Contact	M22520 / 5 - 01 Tool, PIC 190518A Hex Crimp Die (.095 square)
Crimp Ferrule	M22520 / 5 - 01 Tool, PIC 190518A Hex Crimp Die (.272/.340 hex)

Apply the 4:1 Dual Wall Heat Shrink Tubing supplied.

