

PIC Wire & Cable	Connector Specification	P/N 190624
A Division of the Angelus Corporation Ph (262) 246-0500 Fax (262) 246-0450 www.picwire.com PO Box 330 Sussex, WI 53089	Approved : 	Date 10/31/03
	Distribution : USER	Rev. 2 (06/18/14)
		Uncontrolled Document

N In-Line Straight Jack
for S55122

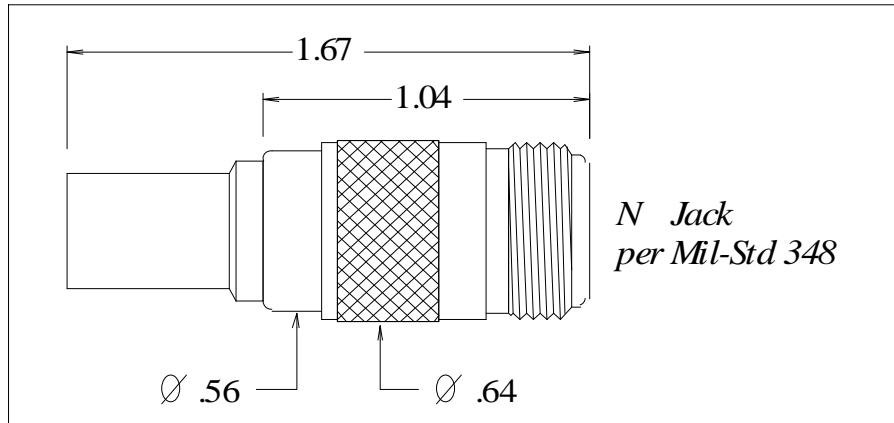

PERFORMANCE

Nominal Impedance	50 Ohms
Frequency Range	0 - 12 GHz
Voltage Rating	1000 VRMS
Insulation Resistance	5000 Megohms

CONNECTOR WEIGHT (Each)

tbd

RoHS COMPLIANT

Complies to RoHS Standards

INSTALLATION

Pic Die Set	MIL Spec Die Set
<i>Center Contact</i>	<i>Center Contact</i>
M22520 / 5 - 01 Tool,	M22520 / 5-01 Tool,
*PIC 190618 Hex Crimp Die	MIL Spec *M22520 / 5-57
(.098 hex)	(.100 B hex)
 <i>Crimp Ferrule</i>	 <i>Crimp Ferrule</i>
M22520 / 5 - 01 Tool,	M22520 / 5-01 Tool,
*PIC 190618 Hex Crimp Die	MIL Spec *M22520 / 5-47
(.359/.432 hex)	(.359 A hex)

* Note - MIL Spec die to be used on the smaller diameter area of ferrule only. Not the larger "Bell" area on end.

CONSTRUCTION

Materials:

Body	Brass, ASTM-B16, Alloy UNS 36000, H02
Center Contact	Beryllium Copper, ASTM-B196, Alloy UNS C17300
Ferrule	Brass, ASTM-B16, Alloy UNS 36000, Dead Soft, Weatherseals included
Dielectric	TFE Fluorocarbon, ASTM-D1710, Type 1, Grade 1

Finish :

Body, Ferrule	Nickel
Center Contact	Gold

Applicable Standards

MIL-STD 348
MIL-PRF-39012

Notes :

- 1) A 2.5" piece of Raychem ATUM heat shrink P/N ATUM-16/4-0 provided with connector for purpose of strain relief & moisture protection.
- 2) Please refer to T-190XXX Termination Instruction sheet for strip dimensions & instructions.

PIC Wire & Cable Connector User specification sheets are non-controlled documents. Please contact PIC Wire and Cable or visit the PIC website (www.picwire.com) to ensure the latest revision of the drawing is being viewed.