

A Division of the Angelus Corporation
 Ph (262) 246-0500 Fax (262) 246-0450 www.picwire.com
 W220 N1051 Springdale Road Waukesha, WI 53186

Approved : *JDA*
 Distribution : USER

Date : 06/22/21
 Rev : 0 (06/22/21)
 Uncontrolled if Printed

TNC Bulkhead Jack
 for S31601

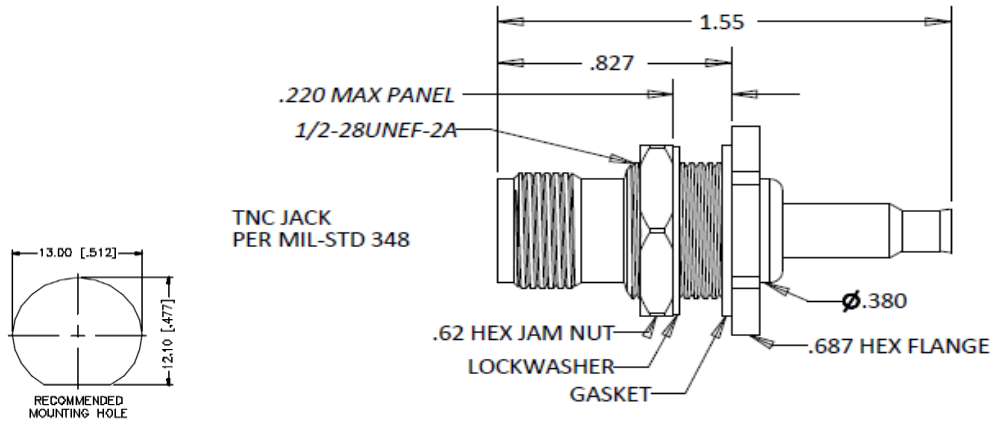

PERFORMANCE

Nominal Impedance	50 Ohms
Frequency Range	0 - 11 GHz
Voltage Rating	500 V(rms)
Insulation Resistance	5000 Megaohms min.
Insertion Loss :	0.06 $\sqrt{F(\text{GHz})}$

CONSTRUCTION

Materials:

Body	Brass
Insulator	PTFE
Gasket	Rubber
Lock Washer	Brass
Hex Nut	Brass
Contact Pin	Phosphor Bronze
Sleeve	Delrin
Ferrule	Copper

CONNECTOR WEIGHT (Each)

.68 ounces (19.3 grams)

Finish :

Body, Ferrule, Lock Washer, Hex Nut	Nickel
Contact Pin	Gold

RoHS COMPLIANT

Complies to RoHS Standards

APPLICABLE STANDARDS

MIL-STD 348
 MIL-PRF-39012

INSTALLATION

Center Contact

M22520/5-01 Hex Crimp Tool or Soldering Equipment
 M22520/5-09 Hex Crimp Die Set
 Cavity B (.068" Hex)

Crimp Ferrule

M22520/5-01 Hex Crimp Tool
 M22520/5-09 Hex Crimp Die Set
 Cavity A (.178" Hex)

Notes :

1) A 1.0" piece of Raychem ATUM heat shrink P/N ATUM-8/2-1.0" provided with connector for purpose of strain relief & moisture protection.

2) Please refer to T-111165 Termination Instruction sheet for strip dimensions & instructions.