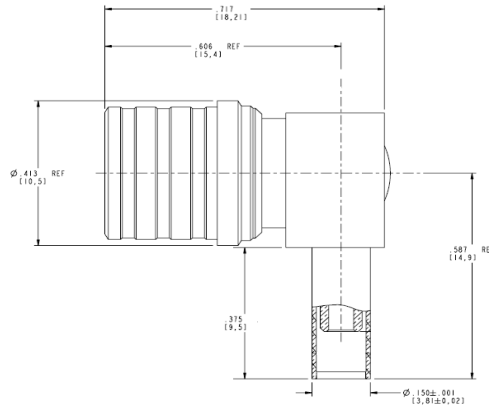

A Division of the Angelus Corporation  
 Ph (262) 246-0500 Fax (262) 246-0450 www.picwire.com  
 W220 N1051 Springdale Road Waukesha, WI 53186

Approved : *JDA*  
 Distribution : USER

Date : 07/14/21  
 Rev : 0 (07/14/21)  
 Uncontrolled if Printed

**QMA 90° Plug Connector**  
 for S31601 Coax Cable

**PERFORMANCE**

Nominal Impedance 50 Ohms  
 Frequency Range DC - 6 GHz  
 VSWR 1.15 + .03F

**CONSTRUCTION****Materials:**

Body	Brass
Outer Contact	Phosphor Bronze
Cap	Brass
Insulator	PTFE
Cable Contact	Brass
Sleeve	Brass
Ferrule	Brass

**CONNECTOR WEIGHT (Each)**

0.30 ounces (8.4 grams)

**RoHS COMPLIANT**

Complies to RoHS Standards

**Finish :**

Body, Ferrule	White Bronze
Center Contact	Gold

**INSTALLATION****Center Contact**

Fine Tip Soldering Iron OR  
 American Beauty # 105A3 Resistance soldering tweezers

**Crimp Ferrule**

M22520/5-01 Crimp Tool  
 M22520/5-08 Crimp Die Set  
 Cavity A (.128" Hex)

**APPLICABLE STANDARDS**

MIL-348, SMA Series

**Notes :**

- 1) A 0.75" piece of Raychem ATUM heat shrink P/N ATUM-8/2 provided with connector for purpose of strain relief & moisture protection.
- 2) Please refer to T-110980 Termination Instruction sheet for strip dimensions & instructions.