

A Division of the Angelus Corporation
 Ph (262) 246-0500 Fax (262) 246-0450 www.picwire.com
 W220N1051 Springdale Road, Waukesha, WI 53186

Approved: *JDA*

Date: 4/28/2021

Rev.: 0

Distribution: USER

Uncontrolled if Printed

Mini-BNC 90° Plug

for V73263

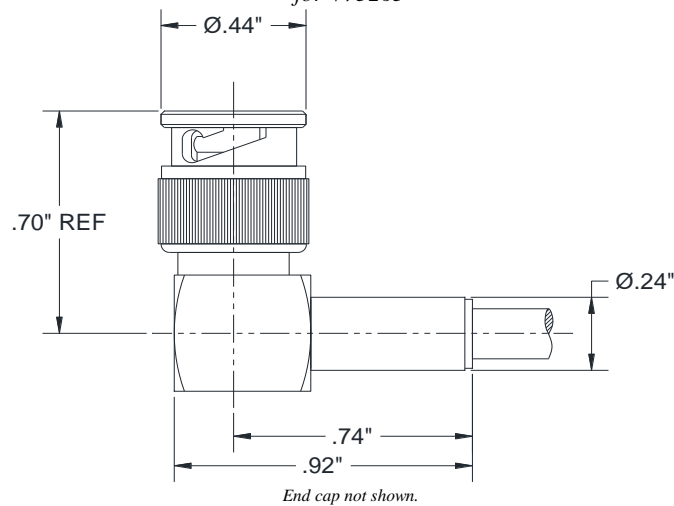

PERFORMANCE

Nominal Impedance :	75 Ohms
Frequency Range :	0 - 3
Voltage Rating :	500 V(rms)
Insulation Resistance :	5000 Megohms min.
Insertion Loss :	$0.10 \sqrt{F(GHz)}$
Temperature Rating :	-40° C to 155° C

CONNECTOR WEIGHT (Each)

0.34 ounces (9.54 grams)

RoHS COMPLIANT

RoHS Compliance is under review.

INSTALLATION

Center Contact

Solder Only

Crimp Ferrule

Tool: M22520/5-01

Die Set: Daniels Y248

(.186" Hex or equivalent)

CONSTRUCTION

Materials:

Body	Phosphor Bronze
Center Contact	Brass
Ferrule	Brass

Finish :

Shell/Body	Nickel
Contact	Gold
Ferrule	Nickel

APPLICABLE STANDARDS

N/A

Notes :

1) A 1.5" piece of Raychem ATUM heat shrink P/N ATUM-8/2-0 provided with connector for purpose of strain relief & moisture protection.

2) Please refer to T-111069 Termination Instruction sheet for strip dimensions & instructions.