

A Division of the Angelus Corporation
 Ph (262) 246-0500 Fax (262) 246-0450 www.picwire.com
 N220 W1051 Springdale Road, Waukesha, WI 53186

Approved : 
 Distribution : USER

Date : 07/06/16
 Rev. 2 (07/21/2023)
 Uncontrolled if Printed

ARINC 600 Modified Size 1 Socket Contact
 for UH67163

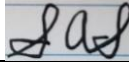
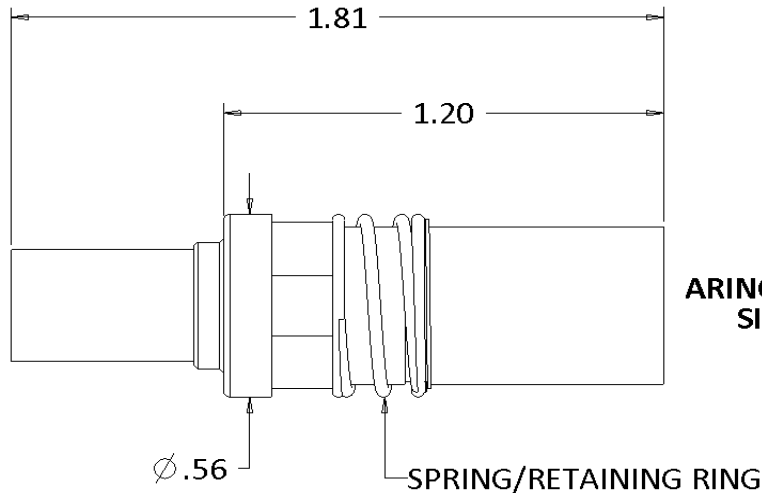

**ARINC 600 MODIFIED
 SIZE 1 SOCKET**

PERFORMANCE

Nominal Impedance	50 Ohms
Frequency Range	0 - 5 GHz
Voltage Rating	1000 V (rms)
Insulation Resistance	5000 Megohms

CONNECTOR WEIGHT (Each)

0.83 ounces (23.47 grams)

RoHS COMPLIANT

Complies to RoHS Standards

INSTALLATION**Center Contact**

Solder Only

Crimp Ferrule

M22520 / 5-01 Tool
 M22520 / 5-41 Die Set
 (.290" A hex)

CONSTRUCTION**Materials:**

Body	Brass, ASTM-B16, Alloy UNS 36000, H02
Center Contact	Beryllium Copper, ASTM-B196, Alloy UNS C17300
Ferrule	Brass, ASTM-B16, Alloy UNS 36000, Dead Soft,
Dielectric	TFE Fluorocarbon, ASTM-D1710, Type 1, Grade 1
Spring, Retaining Ring	Stainless Steel

Finish :

Body, Ferrule	Gold
Center Contact	Gold
Spring, Retaining Ring	Passivated

APPLICABLE STANDARDS

ARINC 600

Notes :

- 1) A 1.5" piece of Raychem ATUM heat shrink P/N ATUM-12/3-0 provided with connector for purpose of strain relief & moisture protection.
- 2) Please refer to T-1505XX Termination Instruction sheet for strip dimensions & instructions.