

PIC Wire & Cable <i>A Division of the Angelus Corporation</i> Ph 262-246-0500 Fax 262-246-0450 PO Box 330 Sussex, WI 53089	Connector Specification	110315
	Approved <i>MCT</i>	Date 04/27/06
	Distribution : USER	Rev. 1 (06/25/13) Uncontrolled Document

SMA Straight Plug
for S29124

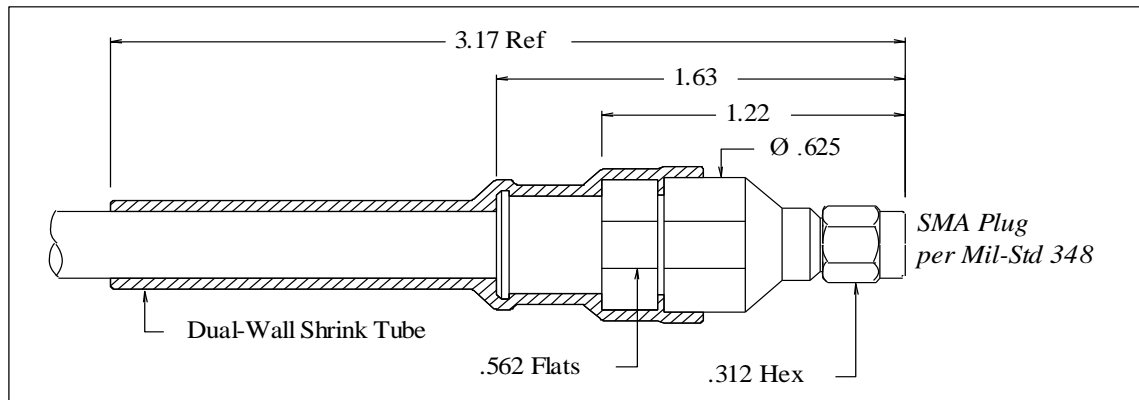

Features Not Shown: Seal in front

PERFORMANCE

Nominal Impedance	50 Ohms
Frequency Range	0 - 18 GHz
Voltage Rating	335 VRMS
Insulation Resistance	5000 Megohms

CONNECTOR WEIGHT (Each)

.944 ounces (26.76 grams)

RoHS COMPLIANT

Complies to RoHS Standards

INSTALLATION

Crimp Tooling:

Solder-on Termination

CONSTRUCTION

Materials:

Body	Stainless Steel
Coupling Nut	Stainless Steel
Center Contact	Beryllium Copper
Dielectric	PTFE Fluorocarbon

Finish :

Body	Passivated
Coupling Nut	Passivated
Center Contact	Gold

Applicable Standards

MIL-STD 348
MIL-PRF-39012

Notes :

1) Please refer to T-110315 Termination Instruction sheet for strip dimensions & instructions.